

The logo for SnT, consisting of the letters 'SnT' in a white, sans-serif font. The 'S' and 'n' are connected, and the 'T' is separate. Below the letters are three short horizontal white bars.

Interdisciplinary Centre
for Security, Reliability
and Trust

Space-Ready OAI 5G NTN Stack: 6GSpaceLab/SnT's Roadmap and Contributions

22 June 2026 – Turker YILMAZ

6GSpaceLab's OAI-related Projects' Timeline

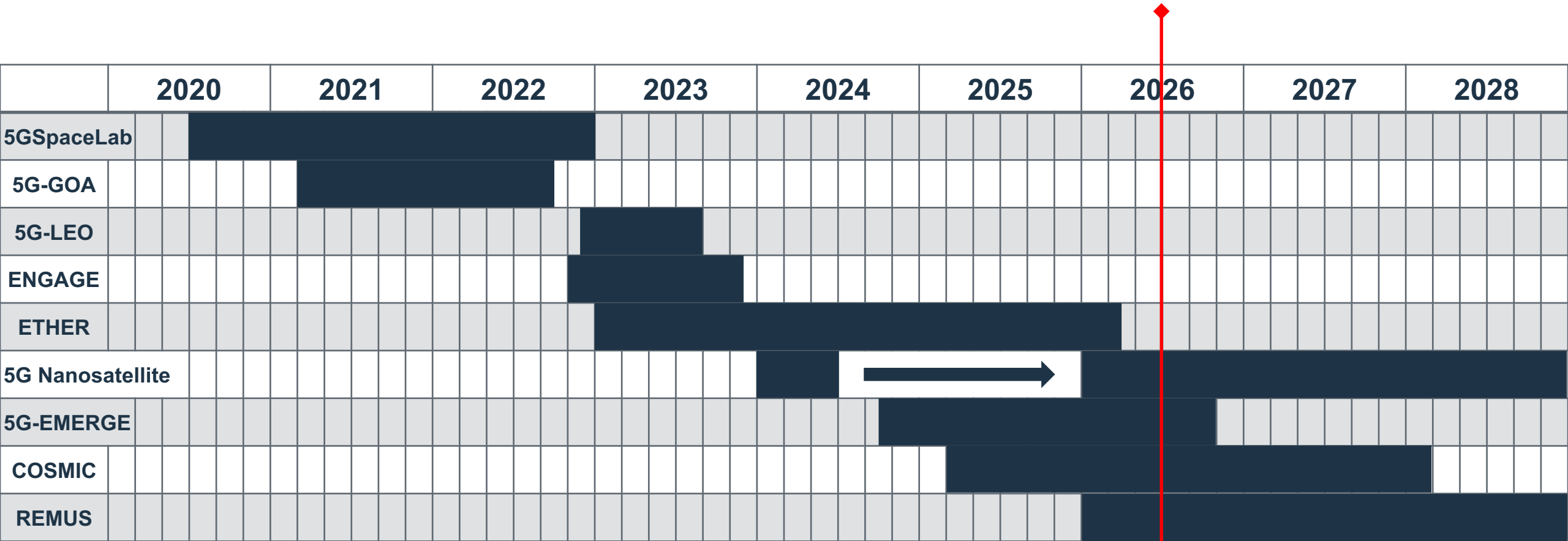

30/06/2026



SnT's OAI Projects 2025 Work

ETHER: sElf-evolving terrestrial/non-Terrestrial Hybrid nEtwoRks

- **Assumptions:**

- Mobile communication only over TN gNBs can be unfeasible due to lack of infrastructure (remote/rural areas) or bad link/high cell traffic.
- It would be beneficial to shut down terrestrial gNBs during low-traffic conditions (e.g., during the night)
- Broadband communications is always necessary for the handheld devices

- **Related innovations:** Direct handheld device access at the Ka-band by leveraging device antenna design and intelligent algorithms for vertical handover between 5G NR terrestrial and non-terrestrial networks.

- **Targeted KPIs:**

- 100% global outdoor coverage,
- 7 9's service continuity and reliability, and,
- >70% more energy-efficient vertical HO w.r.t SotA.

Use Case 2: Unified RAN for direct handheld device access at the Ka-band

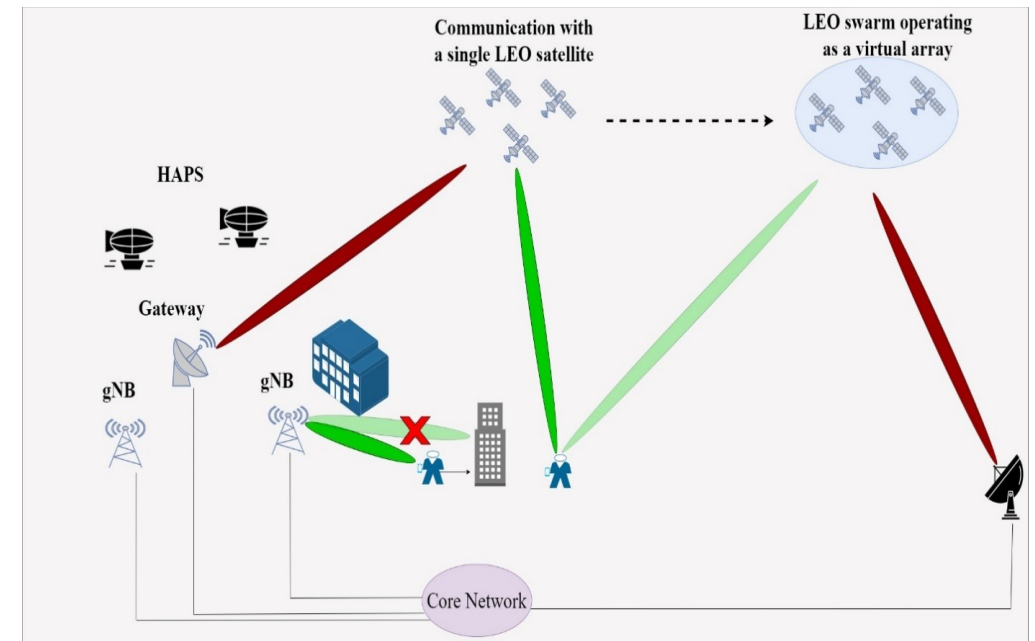

Testbed Schematics and Setup

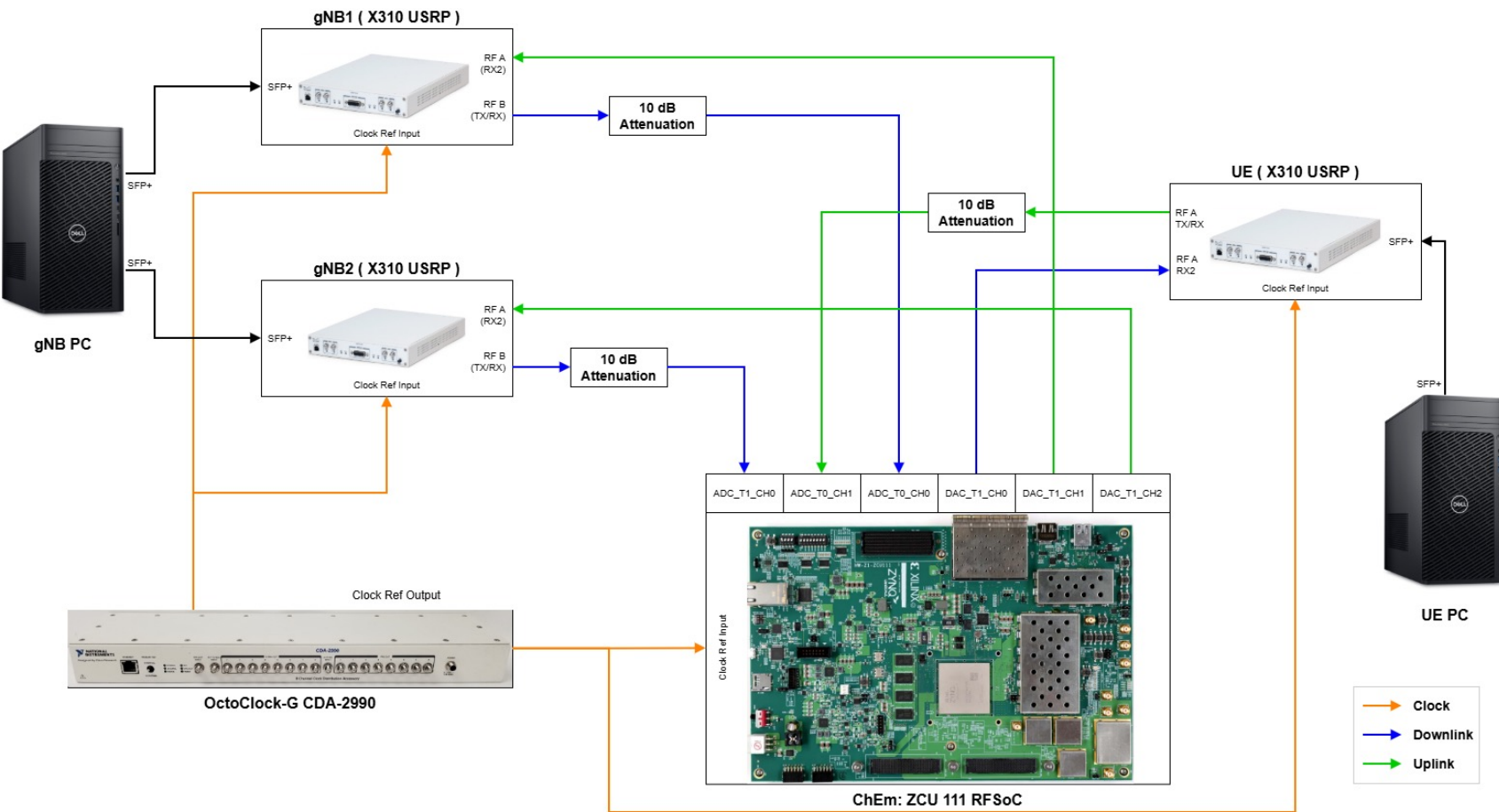

Energy Saving Handover Strategy and Access Network Power Modeling

- HO algorithm design seeks to maximize the net energy reduction (ΔP) of the entire network segment:
 1. **Trigger:** The UE reports that the serving cell signal has dropped below a threshold (Event A2).
 2. **Snapshot:** CU captures the current load (# of UEs) and power state of both the Serving&Target DUs
 3. **Prediction:** Algorithm calculates the expected power consumption of network if HO were to occur
 4. **Gating:** Decision follows QoS&robustness constraints (Hysteresis, SINR, Delay, Switch-off Probability)
 5. **Execution:** If and only if the ΔP is positive and all gates are passed; the HO is executed.

- **ETHER's Affine-with-Load Power Model**

$$P_{total} = N_{TRX} * P_0 + N_{TRX} * \delta_p * P_{out}$$

- N_{TRX} : Number of transceiver (TRX) chains in the BS
- P_0 (mW): Non-zero idling power per TRX chain (Power amplifier (PA) bias, Baseband/RF, cooling share, etc.)
- δ_p is the load-dependent slope (unitless) that captures PA and supply efficiencies
- P_{out} is the radiated RF power that is proportional to allocated PRBs ($P_{out} = P_{RB} * N_{RB}$)

Implementation in OAI 5G NR

- 3GPP F1 split/Split 2 [Central Unit (CU) component] is targeted: It is advantageous for energy management since the CU-CP aggregates data from multiple DUs – it knows the load status of the entire cluster:
 - gNB-CU-CP (Control Plane): Handles RRC and PDCP, and where the decision logic resides.
 - gNB-DU (Distributed Unit): Handles RLC, MAC, and PHY. It provides the measurements.
- 1. **Energy Configuration Scaffolding:**
 - *openair2/GNB_APP/gnb_paramdef.h*: Added new configuration keys.
 - *openair2/GNB_APP/gnb_config.c*: Added logic to parse and log these keys.
 - *openair2/RRC/NR/rrc_gNB.c*: Added logic to sanitize and store them in the RRC instance.
- 2. **The Energy Metrics:** To persist the energy state of each UE and cell, in *openair2/RRC/NR/nr_rrc_defs.h* new data structures were introduced. Every connected UE carries its own constantly updated “energy potential” passport.
- 3. **The Logic Core:** *rrc_evaluate_energy_ho* function in *openair2/RRC/NR/rrc_gNB.c* is invoked whenever an A2 Event report arrives. It orchestrates the gating logic described previously.
- 4. **Integration with Event A2 Processing:** *process_Event_Based_Measurement_Report* function (RRC layer) was modified to hook into the energy evaluator: previously, receiving an A2 report might simply trigger a blind HO; the new logic injects the energy check. This insertion point ensures that all mobility events are filtered through the energy policy without disrupting the underlying RRC ASN.1 encoding/decoding machinery.

Experimental Verification and Log Analysis



```
DCI, RA RNTI 0x113, state 1, preamble_index(RA
PID) 63, timing_offset = 0 (estimated distance
0.0 [m])
[NR_MAC] 590.10 Send RAR to RA-RNTI 0113
[NR_MAC] 59111: RA RNTI 03ea CC_id 0 Schedu
ling retransmission of Msg3 in (591,17)
[NR_MAC] 59211: RA RNTI 03ea CC_id 0 Schedu
ling retransmission of Msg3 in (592,17)
[NR_MAC] 59311: RA RNTI 03ea CC_id 0 Schedu
ling retransmission of Msg3 in (593,17)
[NR_MAC] UE 03ea RA failed at state WAIT_Msg
3 (Reached msg3 max harq rounds)
[NR_MAC] Remove NR rnti 0x03ea
[GTPU] [94] UE ID 6899: Delete all tunnels (
1 tunnels)
[RLC] Remove UE 6899
[NR_MAC] Remove NR rnti 0x1af3
[GTPU] try to get a gtp-u not existing output
[NR_MAC] Frame.Slot 640.0
```

```
57b
[NR_MAC] DU received confirmation of success
ful RRC Reconfiguration
[NR_MAC] Frame.Slot 640.0
UE RNTI f57b CU-UE-ID 1 in-sync PH 48 dB PCMAX
20 dBm, average RSRP -44 (3 meas)
UE f57b: dlsch_rounds 1/0/0/0, dlsch_errors 0,
pucch0_DTX 0, BLER 0.10000 MCS (0) 0 CCE fail
0
UE f57b: ulsch_rounds 10/0/0/0, ulsch_errors 0
, ulsch_DTX 0, BLER 0.06561 MCS (0) 0 (Qm 2 de
ltaMCS 0 dB) NPRB 5 SNR 42.0 dB CCE fail 1
UE f57b: MAC: TX 21 RX
124 bytes
UE f57b: LCID 1: TX 3 RX
10 bytes
UE f57b: LCID 2: TX 0 RX
0 bytes
UE f57b: LCID 4: TX 0 RX
0 bytes
```

turker@ul0011627: ~/Documents/ETHER/v4/cmake_targets/ran_build/build 94x22

```
[NR_RRC] Energy RNG: UE 1 clearing outstanding transactions to enable future HO
[NR_RRC]
ENERGY RNG: UE 1 -> target PCI 1 | switch=0.89 sinr=4.42 delay=7.84 | decision=accepted [overr
ide ΔP 1264.7 mW >= hysteresis 1000.0, switch 0.89 >= 0.70, sinr 4.42 >= 3.00, delay 7.84] {ac
tion=triggered} (ΔP 1264.7 mW)
```

```
[NR_RRC] Handover triggered for UE 1/RNTI 1af3 towards DU 3585/assoc_id 14/PCI 1
[RRC] UE 1af3 replacing existing CellGroupConfig with new one received from DU
[E1AP] UE 1: updating PDU session ID 10 (1 bearers)
[PDCP] DRB 1 re-established
[GTPU] [95] UE ID 1: Update tunnel TEID incoming 43fcc6c2 outgoing ddb45ee5 to remote IPv4 1
27.0.0.5, IPv6 ::, port 2152
[NR_RRC] HO acknowledged: Send reconfiguration for UE 1/RNTI 1af3...
[PDCP] SRB 2 re-established
[RRC] UE 1: PDU session ID 10 modified 1 bearers
[NR_RRC] UE 1 handover: update RNTI from 1af3 to f57b
[NR_RRC] [UL] (cellID 5397fb1, UE ID 1 RNTI f57b) Received RRCReconfigurationComplete
[NR_RRC] handover for UE 1/RNTI f57b complete!
[NR_RRC] UE 1 Handover: trigger release on DU assoc_id 12
```

turker@ul0011627: ~/Documents/ETHER/v4/cmake_targets/ran_build/build 94x22

```
[PHY] HW: Configuring channel 0 (rf_chain 0): setting tx_freq 3649440006 Hz, rx_freq 3649440
006 Hz, tune_offset 0
[PHY] Got synch: hw_slot_offset 12, carrier off 6 Hz, rxgain 0.000000 (DL 3649440006.000000
Hz, UL 3649440006.000000 Hz)
[PHY] UE synchronized! decoded_frame_rx=584 UE->init_sync_frame=0 trashed_frames=4
[PHY] Resynchronizing RX by 182096 samples
[HW] received write reorder clear context
[MAC] Initialization of 4-Step CFRA procedure
[NR_MAC] PRACH scheduler: Selected RO Frame 589, Slot 19, Symbol 8, Fdm 0
[PHY] PRACH [UE 0] in frame.slot 589.19, placing PRACH in position 2828, Msg1/MsgA-Preamble
frequency start 0 (k1 0), preamble_offset 15, first_nonzero_root_idx 0, preambleIndex = 63
[PHY] [UE 0] RAR-Msg2 decoded
[NR_MAC] [UE 0][RAPROC][RA-RNTI 0113] Got BI RAR subPDU 5 ms
[NR_MAC] [UE 0][RAPROC][RA-RNTI 0113] Got RAPID RAR subPDU
[NR_MAC] [UE 0][RAPROC][590.10] Found RAR with the intended RAPID 63
[MAC] received TA command 31
[MAC] [UE 0][590.10][RAPROC] RA procedure succeeded. CFRA: RAR successfully received.
[NR_MAC] UE 0 RNTI f57b stats sfn: 640.8, cumulated bad DCI 0
DL harq: 12/0
UL harq: 84/0 avg code rate 0.1, avg bit/symbol 2.1, avg per TB: (nb RBs 16.1, nb symbols
9.3)
```

SnT's OAI Projects 2026 Work Plan

REMUS: Enhanced REliability and Service Continuity of MULTI-Orbital Satellite Networks

- **Aims:**

- To advance Multi-Orbit (MO) systems jointly with multi-connectivity (MC), to enable the UE to maintain multiple simultaneous links across orbits.
- To address single connectivity issues such that reliability enhancement (packet duplication), to meet ultra-reliable requirements.
- To develop MC framework through HO techniques (e.g., soft HO) that are designed for SES's MO scenarios.

- **Final Objective:** To improve quality of service with ultra-reliability and seamless intra/inter-orbit mobility considering various network conditions and unique characteristics of MO.

- **Envisioned Setup:** 3 gNBs (1 Master Node [MN] and 2 Secondary Nodes [SNs]) and 1 UE

- **Realisation via OAI:** F1 NR-DC is compulsory to be implemented

- As of today, this feature is only enabled through F1AP, while dual separate gNBs would need XnAP implementation.
- To develop MC framework, new HO algorithms will be needed to add/release SNs while keeping MN in charge of control

No single orbit satisfies all connectivity requirements

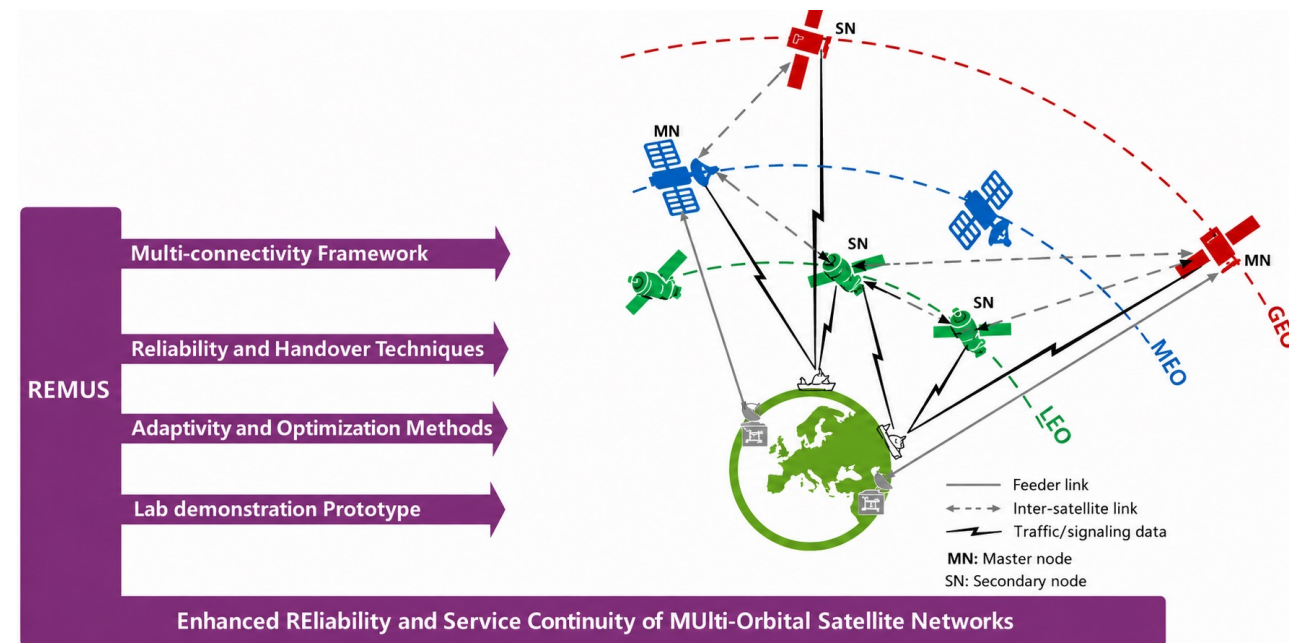

5G Nanosatellite

- **ESA ARTES 4.0 SPL – SPACE FOR 5G (01/2024 to 12/2028)**
- **Goal:** Develop and demonstrate in-orbit a 5G UE (terminal) nanosatellite subsystem that can be integrated into LEO satellites and capable of connecting to 5G networks on Earth.
- **Objectives:**
 - Evaluate the performance and feasibility of having a 5G UE terminal based on OAI which runs on a Raspberry Pi Compute Module 5 and USRP B205mini for the RF frontend, embedded on a 3U cubesat orbiting at a Sun-synchronous Orbit around 500 km of altitude.
 - Evaluate in a real orbital testbed the adjustments and customizations that must be carried out to compensate the effect of Link Loss, Doppler Effect and Round-Trip Delay.
 - Productize a 5G UE sub-system + antenna that can later be re-used by other nanosatellite developers.
 - Productize a 5G gNB + Antennas dedicated to NTN.

Frequency Band	n28 (763-768 MHz DL / 708-713 MHz UL]
Duplexing	FDD
SCS	15 kHz
PRB (Bandwidth)	25 (5 MHz)
FFT Size	512
Sampling Rate	7.68 Msps
RTT	>4 ms (>2x600 km)
Modulation Order	2 (QPSK)
IQ Bitwidth	2 x 16 bits
MIMO Layers & Antenna Ports	= 1
Doppler (for n28)	<±18 kHz(@7km/s)
SNR	>3 dB
Throughput	1Mbps DL&UL@APP

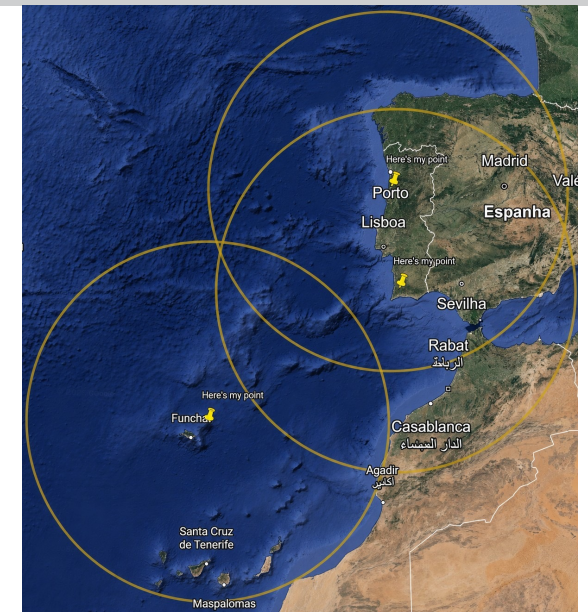

Technology Phase Project Work Plan

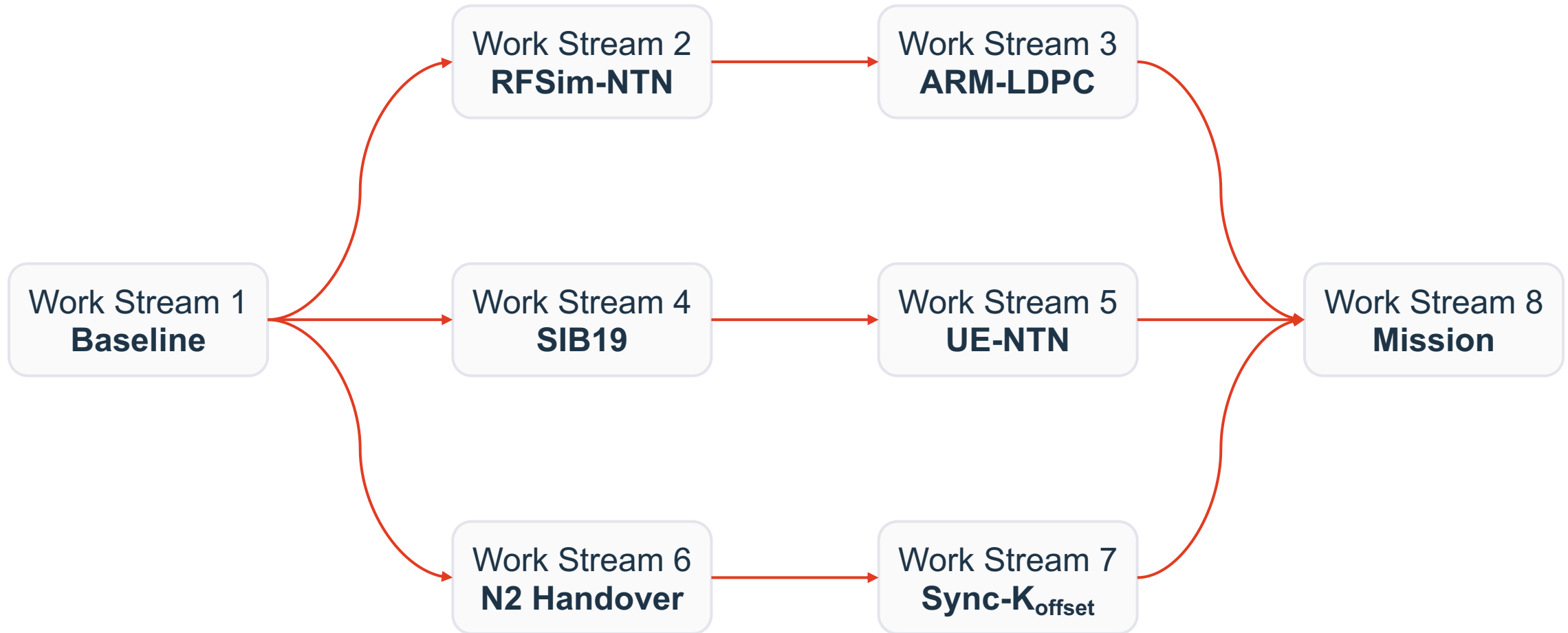

WS1: Build, Runtime & Mission Profile Freeze

- **T01: Baseline build/runtime characterization on x86 and CM5**
 - Project Need: Create the “before changes” reference so every later improvement or regression can be measured scientifically on both the lab x86 platform and the target CM5 UE platform.
 - OAI Status: gNB and UE softmodems are buildable, but a full measured runtime baseline on x86 and CM5 is still needed, including attach, throughput, CPU/thermal behavior, USB stability, logs, and reproducible build metadata.
- **T02: Add project-specific UE/gNB configuration profiles for mission baseline**
 - Project Need: Convert the 5G-Nanosatellite assumptions into deterministic profiles so all experiments use the same Band n28, FDD, 5 MHz, 25 PRB, CM5/B205mini, gNB, handover, and traffic settings.
 - OAI Status: Generic examples and partial NTN profiles are available, but a complete, project-specific, hashable profile set for the exact mission baseline and test campaign is still needed.
- **T03: Define the no-touch UE/gNB softmodem service profile**
 - Project Need: Make the UE and gNB behave like mission equipment: power up, start automatically, reconnect where possible, and fail in a controlled way without continuous operator intervention.
 - OAI Status: Softmodem binaries and service-style examples are available, but a 5G-Nanosatellite no-touch service contract with explicit configs, radio binding, health checks, restart policy, and logs is still needed.
- **T04: Characterize UE RX_GAIN AGC and define a mission AGC alternative**
 - Project Need: The nanosatellite UE must remain synchronized under changing received power, so RX gain control must be bounded, observable, and stable with the B205mini-i frontend.
 - OAI Status: An NR UE AGC path and USRP gain setters are available, but convergence, limits, hysteresis, synchronization interaction, and mission suitability still need to be characterized and measured.
- **T05: Add UE TX_GAIN startup, live update, and persistent default control**
 - Project Need: UE transmit power must be reproducible at startup and adjustable during lab tests without restarting the UE, while still allowing the default to be changed remotely for future boots.
 - OAI Status: Startup TX gain configuration and USRP gain application are supported, but validated live TX gain control and persistent remote default-update paths are still needed for this project.

WS1: Build, Runtime & Mission Profile Freeze

- **T06: Calibrate USRP B205mini frame-delay behavior**
 - Project Need: Timing calibration is required so the gNB and UE B205mini radios do not hide hardware delay errors inside NTN timing, random-access, or handover results.
 - OAI Status: USRP timing and calibration hooks are available, but serial-numbered frame-delay/sample-advance calibration records and before/after evidence are still needed for the physical project radios.
- **T07: Implement the UE watchdog health model and recovery policy**
 - Project Need: The satellite UE must recover from stalled or failed states in orbit-like no-touch operation, while avoiding unnecessary restart loops during normal RF or network recovery.
 - OAI Status: Useful UE state and failure indicators are exposed, but a project UE watchdog policy for feed, recovery, and restart decisions is still needed.
- **T08: Implement the gNB watchdog health model and recovery policy**
 - Project Need: Ground gNBs must remain serviceable during long lab and mission campaigns, and failures must be detected as cell/core/user-plane health problems rather than only process crashes.
 - OAI Status: gNB, NGAP, MAC, RF, and user-plane signals are exposed, but a 5G-Nanosatellite gNB watchdog policy with conservative restart criteria is still needed.
- **T09: Define safe runtime parameter control over SSH**
 - Project Need: Lab campaigns need controlled runtime adjustment of gains, thresholds, timing biases, and test parameters without turning every experiment into a full softmodem restart.
 - OAI Status: Telnet/control infrastructure is available, but each live-change parameter still needs an explicit safety classification, locking model, readback path, and rejection behavior.
- **T10: Compare B205mini internal clock and GPSDO/10 MHz reference stability**
 - Project Need: Before interpreting Doppler, timing advance, or handover stability, we must know whether the UE B205mini internal clock is sufficient or a GPSDO/10 MHz reference is required.
 - OAI Status: Clock/time-source selection is supported, but measured internal-clock versus external-reference evidence is still needed under the mission radio profile.

WS2: Reproducible Channel & Scenario Model

- **T11: Extend RFSim NTN scenario descriptor and strict parser validation**
 - Project Need: RFSim NTN experiments must be replayable and scientifically interpretable, not dependent on hidden defaults for orbit, geometry, delay, Doppler, seed, or link-budget assumptions.
 - OAI Status: LEO/GEO RFSim primitives are available, but a complete versioned scenario descriptor with strict validation and clear startup diagnostics is still missing.
- **T12: Implement selectable NTN delay-model pipeline**
 - Project Need: NTN timing claims require an explicit delay model so static, time-varying, integer-sample, and fractional-delay behavior can be separated and measured.
 - OAI Status: RFSim propagation delay and LEO dynamic delay can be applied, but clearer selectable delay modes and an explicit error budget are still needed.
- **T13: Generalize orbit/geometry and Doppler replay**
 - Project Need: Reproducible LEO pass geometry for multiple real ground gNB sites required, not only a simplified hardcoded satellite model.
 - OAI Status: Circular LEO Doppler/delay support is available, but mission geometry, fixed seeds, replay controls, and three-gNB site modeling still need to be generalized.
- **T14: Add calibrated link-budget/noise model extensions**
 - Project Need: SNR, path loss, and noise conditions must map to physical mission assumptions so throughput, BLER, and handover claims are meaningful.
 - OAI Status: Basic RFSim path loss and noise controls are supported, but a calibrated 5G-Nanosatellite link-budget/noise mode with reproducible SNR campaign points is still needed.
- **T15: Add RFSim NTN telemetry and orchestration hooks**
 - Project Need: Delay, Doppler, position, velocity, SNR, and scenario state must be captured as data so RFSim runs can be replayed, verified, and converted into publication figures.
 - OAI Status: Some RFSim/NTN behavior is logged, but a versioned telemetry format and orchestration hooks suitable for automated campaigns are still needed.

WS3:CM5 UE Performance&Transport Pressure

- **T16: Add LDPC decoder instrumentation**
 - Project Need: The CM5 UE feasibility question depends strongly on the CPU LDPC decoder, so decode time, iteration behavior, early stop, BLER, thermal state, and the exact decoder path in use (libldpc.so, or a later CM5-specific alternative if measurements justify it) must be measured first.
 - OAI Status: Some LDPC timing & iteration-related data are exposed, but a complete per-run CM5-ready LDPC evidence table is needed.
- **T17: Implement low-risk adaptive LDPC iteration policy**
 - Project Need: The CM5 has limited CPU and thermal margin, so LDPC work should be reduced when conditions allow without hiding decode failures or damaging BLER.
 - OAI Status: Static LDPC iteration limits are supported, but an opt-in,deterministic adaptive policy backed by A/B measurements is needed
- **T18: Benchmark and, only if needed, add an AArch64 optimized LDPC path**
 - Project Need: AArch64 optimization should be driven by measured CM5 bottlenecks, not assumed, because LDPC changes carry correctness and maintenance risk.
 - OAI Status: Generic and SIMD-related LDPC paths plus Arm-related build hooks are available, but the CM5 performance gap and need for a new optimized path remain unproven.
- **T19: Optimize UE runtime scheduling profile for CM5**
 - Project Need: Even if LDPC is efficient, the UE can fail from scheduling jitter, CPU contention, thermal throttling, or poor thread placement on the CM5.
 - OAI Status: UE actor/thread-pool controls are exposed, but a measured CM5 runtime profile for deadline stability under mission traffic is still needed.
- **T20: Optimize USRP B205mini USB transport profile on CM5**
 - Project Need: The B205mini USB3 path can consume CPU and cause overflows/underflows, so transport settings must be tuned before claiming stable 1 Mbps satellite UE operation.
 - OAI Status: B200-family transport defaults are available, but a mission-specific B205mini/CM5 transport profile with USB and metadata-error evidence is still needed.

5G NR UE Profiling on RPi CM5 & B205mini

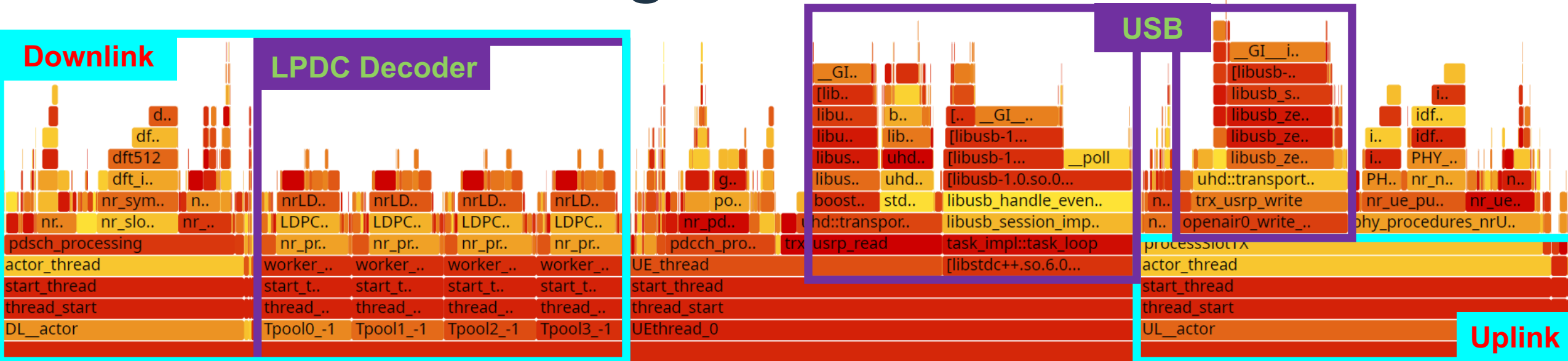

- **Flame Graph:** Hierarchical visualization of the CPU cycles across functions.
 - Above each thread bar, call stack is visualized with the functions invoked by the thread, and the width is proportional to the CPU cycles consumed.
 - *Figure:* MCS 0, bidirectional 1 Mb/s traffic, and we configured the application to use 4 worker threads for LDPC coding.
- DL processing takes 41% (**rises to 61% at MCS 9**), UL processing takes 19%, and USB processing takes 30% of the time, with higher layer threads and the application thread consuming the rest.
- The excessive activity of USB libraries suggests that the transport layer is a primary limiter when scaling to larger BWs:
 - Computationally intensive signal processing algorithms, and,
 - Data transfer to and from the USRP, exhaust the processing budget.

WS4:NTN Broadcast Configuration&UE Delivery

- **T21: Add strict NTN/SIB19 config sanity checks**

- Project Need: Invalid NTN assistance data can silently corrupt timing behavior, so SIB19 and related NTN fields need strict units, ranges, and cross-field validation.
- OAI Status: A narrow SIB19 configuration path is supported, but malformed or inconsistent mission configurations still need stronger diagnostics and rejection tests.

- **T22: Add controlled lab flags for non-standard NTN signaling**

- Project Need: The project may need lab-specific NTN signaling in Band n28, but those deviations must be explicit, opt-in, and separated from standards-default behavior.
- OAI Status: Partial NTN access behavior is available, but project-level lab override flags with clear logs®ression evidence are needed.

- **T23: Introduce a dedicated SIB19 internal configuration model**

- Project Need: Static policy, dynamic satellite state, and encoded ASN.1 state must be separated so SIB19 behavior is predictable and safe during updates.
- OAI Status: Several SIB19 concerns are still mixed close to encoding/runtime structures; a cleaner mission-domain model is still needed.

- **T24: Wire parser and lifecycle support for missing SIB19/NTN fields**

- Project Need: Rel-17 NTN fields must be configurable, validated, allocated, freed, encoded, and tested instead of silently omitted.
- OAI Status: Some SIB19 fields are supported (*ntn-UISyncValidityDuration-r17*, *cellSpecificKoffset-r17*, *ta-Common-r17*, *ta-CommonDrift-r17*, and *positionVelocity-r17 position/velocity ephemeris*), but several optional mission fields (**ta-CommonDriftVariant-r17**, **kmac-r17**, **ta-Report-r17**, **ntn-PolarizationDL-r17**, **ntn-PolarizationUL-r17**, **t-Service-r17**, **referenceLocation-r17**, **distanceThresh-r17**, and **ntn-NeighCellConfigList-r17**) still need parser/lifecycle wiring and presence-combination tests.

- **T25: Implement SIB1 NTN-access policy and override control**

- Project Need: UE NTN-mode access must be intentional and reproducible, especially when lab Band n28 behavior differs from standards-default NTN band assumptions.
- OAI Status: NTN access logic is available, but a policy function and explicit override behavior for the project lab profile are still needed.

WS4:NTN Broadcast Configuration&UE Delivery

- **T26: Complete and validate gNB SIB19 encoding**
 - Project Need: The gNB must broadcast the exact NTN assistance that the UE needs for delay, timing advance, drift & ephemeris behavior
 - OAI Status: A narrow SIB19 baseline is encoded, but full mission field coverage, configurable SIB19 broadcast behavior, and encode/decode roundtrip evidence remain to be completed.
- **T27: Split static and dynamic SIB19 update paths**
 - Project Need: Dynamic satellite timing updates must not accidentally overwrite static mission policy fields or leave stale encoded state.
 - OAI Status: Dynamic SIB19-related code paths are available, but static policy and dynamic epoch/TA/drift updates still need clearer separation and tests.
- **T28: Define ephemeris mode policy**
 - Project Need: The project needs one defensible way to represent satellite state, such as position/velocity baseline behavior, and clear rules for unsupported orbital inputs.
 - OAI Status: Position/velocity style NTN data are supported, but the mission policy for ephemeris modes and fallback behavior still needs to be fixed and tested.
- **T29: Extend UE/FAPI consumption for newly used SIB19 fields**
 - Project Need: Broadcasting NTN fields is not enough; the UE and FAPI-facing structures must either consume them or explicitly report that they are currently no-ops.
 - OAI Status: Some SIB19-derived NTN data are consumed, but newly enabled fields still need UE/FAPI representation.
- **T30: Validate scheduler and SI payload behavior for SIB19**
 - Project Need: SIB19 must be scheduled and received reliably, otherwise NTN assistance may exist in configuration but not reach the UE at the right time.
 - OAI Status: SIB19 scheduling support is available, but payload index, SI window, periodicity, grouping, and dynamic update latency still need measured validation.

WS5: UE Timing, Doppler, and Telemetry

- **T31: Harden UE NTN TA/Doppler compensation**
 - Project Need: The UE must handle LEO-relevant delay, drift, and Doppler without overflow, stale data, divide-by-zero behavior, or unstable timing corrections.
 - OAI Status: SIB19-derived NTN data are consumed and timing/frequency corrections are applied, but corner-case guards and stress evidence remain incomplete.
- **T32: Implement UE Doppler compensation mode architecture**
 - Project Need: Doppler compensation strategies must be selectable and comparable so the project can justify the mode used for the nanosatellite UE.
 - OAI Status: UE frequency correction controls are available, but a clean mode architecture for fractional, integer, measurement-only, or LO-assisted strategies is still needed.
- **T33: Add UE NTN telemetry counters and parseable logs**
 - Project Need: UE NTN behavior must be observable during normal operation and failure, otherwise timing, Doppler, SIB19, and handover claims cannot be verified.
 - OAI Status: Some UE NTN behavior is logged, but stable telemetry fields for SIB19, Koffset, TA, drift, Doppler, residual carrier frequency offset (CFO), correction limit/clamp events, and target-cell transitions are still needed.

WS6:HO Correctness, Orchestration&Evidence

- **T34: Harden NGAP Handover Command PDU-session decode**
 - Project Need:N2 handover cannot be trusted if malformed or edge-case PDU-session HO data can corrupt state or produce silent failures
 - OAI Status: The main IE lookup fix appears to be included, but residual bounds checks, malformed-input tests, and failure-state cleanup still need to be proven.
- **T35: Implement NGAP HandoverPreparationFailure receive path**
 - Project Need: Failed handover preparation is a standard procedure outcome, and campaigns need to classify it cleanly instead of losing the failure inside logs.
 - OAI Status: HO support is available, but the unsuccessful preparation path still needs decode, ITTI dispatch, RRC cleanup, and telemetry.
- **T36: Implement measurement and geometry policy sweep for N2 handover**
 - Project Need: LEO handover should compare RF-only, geometry-assisted, and hybrid policies because satellite motion is predictable and gNB locations are fixed.
 - OAI Status: Current A3 and telnet-triggered handover workflows are supported, but geometry-based target prediction and hybrid policy ranking still need to be added and measured.
- **T37: Add time-aligned and geometry-aware N2 HO telemetry**
 - Project Need: Every handover decision must be explainable using protocol stages, synchronized time, UE position, gNB geometry, and target-selection rationale.
 - OAI Status: RRC/NGAP logs are available, but a complete geometry-aware, time-aligned handover timeline suitable for parser validation is not yet generated.
- **T38: Implement UE T304 expiry recovery**
 - Project Need: Handover failure must drive deterministic UE recovery rather than silent timer expiry or indefinite loss of service.
 - OAI Status: UE HO timer handling is available, but T304 expiry behavior still needs a complete recovery path and fault-injection evidence.

WS6:HO Correctness, Orchestration&Evidence

- **T39: Correct source-history semantics and optional-IE handling**
 - Project Need: Multi-gNB handover campaigns require correct source/target context, PDU-session state, source history, and optional-IE treatment across attempts.
 - OAI Status: N2 handover context handling is available, but optional-field semantics and stale source/target state still need a focused review and invariants.
- **T44: Build deterministic HO orchestrator manifest and trigger runner**
 - Project Need: Handover trials must be replayable and comparable, not manually triggered with undocumented timing and operator-dependent decisions.
 - OAI Status: Telnet-triggered handover is supported, but a manifest-driven runner with repeatable trigger timing, retry rules, and phase gates is still needed.
- **T45: Add HO metadata parser and metric aggregator**
 - Project Need: Raw handover logs must become quantitative evidence: stage timing, interruption windows, missing stages, failures, and per-run summaries.
 - OAI Status: Logs are produced, but a 5G-Nanosatellite parser and aggregator for handover metrics is still needed.
- **T46: Add deterministic HO campaign gates and evidence-integrity checks**
 - Project Need: Handover success claims should pass objective gates for trigger timing, control-plane consistency, missing stages, retries, and artifact completeness.
 - OAI Status: Handover tests can be run, but one-command campaign pass/fail checks and evidence-integrity validation are still needed.

WS7: Scheduling Time & RF Reference Discipline

- **T40: Prove large- K_{offset} safety across gNB scheduling paths**
 - Project Need: NTN scheduling offsets are large, and every gNB MAC path that schedules UL, UCI, RA, SRS, HARQ, or maps timing must remain safe under those offsets.
 - OAI Status: *cellSpecificKoffset_r17* is applied in many gNB scheduling paths, but worst-case offset, wraparound, and map-size behavior still need proof.
- **T41: Validate end-to-end K_{offset} synchronization boundaries**
 - Project Need: RFSim delay, SIB19 K_{offset} , UE timing advance, and gNB scheduler timing must agree as one system for NTN operation to be scientifically valid.
 - OAI Status: The required components are present, but cross-layer timing traces and boundary tests are still needed to prove consistency.
- **T42: Add USRP 10 MHz/PPS telemetry and bounded startup**
 - Project Need: Local radio startup must clearly separate 10 MHz frequency discipline from 1PPS device-time alignment so external-reference behavior is deterministic and diagnosable.
 - OAI Status: USRP clock/time-source settings and reference-lock checks are supported, but bounded waits, alignment-policy logs, PPS self-tests, and reference-loss telemetry still need to be added.
- **T43: Define inter-gNB PPS/PTP frame synchronization and geometry-assisted handover timing**
 - Project Need: Multi-gNB handover needs a common time/frame reference, fixed gNB coordinates, and UE GNSS position/velocity so handover timing can be predicted, triggered, and verified.
 - OAI Status: Local timing hooks and handover support are available, but the system-level clock-domain map, PTP/PPS architecture, coordinate registry, and geometry-assisted handover timing evidence are still missing.

WS8: Application Continuity & Publication Evidence

- **T47: Build mission-traffic E2E test framework**

- Project Need: The final demonstration is application continuity, so video, file transfer, heartbeat, transport metrics, and handover triggers must run together in one campaign.
- OAI Status: General ping/iperf-style tooling is available, but no project test framework yet combines mission traffic, handover timing, telemetry, and artifact capture.

- **T48: Add campaign regression gates and pass/fail evaluator**

- Project Need: The campaign must produce objective pass/fail decisions for control-plane progress, IP continuity, throughput, file integrity, telemetry validity, and artifact completeness.
- OAI Status: Raw experiment data can be generated, but a campaign evaluator is still needed to turn artifacts into strict, research, or smoke-profile results.

- **T49: Final reproducibility package and publication-ready evidence bundle**

- Project Need: The project output must be independently reproducible and verifiable, with commands, configs, hashes, logs, metrics, PCAPs where available, figures, negative results, and limitations.
- OAI Status: The roadmap has been defined in the local plan, but the final replay package, artifact checksum list, runbook, and publication evidence bundle remain to be assembled after implementation.



Interdisciplinary Centre
for Security, Reliability
and Trust

Thank you.